

TMX 20 Series

BAGGAGE
TRACTOR



DESCRIPTION

The TMX20 Series baggage towing tractors are designed for towing baggage and cargo trailers. The maximum draw bar pull is 2 000 daN (4 500 lbs) (TMX20) or 2 400 daN (5 400 lbs) (TMX24). This unit features a heavy duty frame made of arc-welded steel plate with rear heavy cast iron body to achieve long operating life. The TMX20 Series is ergonomically designed to provide maximum driving comfort and excellent all-round visibility.

STANDARD FEATURES

- **Engine** : PERKINS 104-22, 4 cylinders diesel engine 37 kW (50 hp) @ 2 800 rpm
Maximum torque of 140 Nm (103 lbs.ft) @ 2000 rpm
- **Transmission** : ZF 4HP22 automatic transmission equipped with 3 forward speeds up to 25 kp/h (15.6 mph) and 1 reverse gear up to 13 kp/h (8 mph) when empty
- **Front axle** : Steering axle with leaf spring suspension
- **Rear axle** : Driving axle with double speed reducing gear and leaf spring suspension
- **Brake (Service)** : Front brake with discs brake and calliper on front axle, and rear brake with wet discs in the rear axle.
- **Brake (Parking)** : Immersed disc brake on rear axle, mechanically actuated by a cable.
- **Steering** : Power steering.
- **Tow hitch** : Rear 3 levels hitch : 310 mm (12.2''), 400 mm (15.8''), 490 mm (19.3'')
Manual pin : 30 (2.95'')
- **Tyres** : Front: 155/70 R12 XCX (van)
Rear: 205/75 R14 XCA (van)
- **Fuel tank capacity** : 40 liters (10.5 US Gal)
- **Paint** : white – RAL 9016

ELECTRICAL EQUIPMENT

12VDC electrical system equipped with following equipment :

- 12 V 95 Ah battery
- 55 A alternator
- 2 front head lights
- 2 tail lights and 2 stop lights
- Front and rear turn signal lights (+ hazard lights)
- Flashing beacon
- Back-up light

Specifications may be altered as a constant effort to improve performance.

Tolerance of data : +/- 3 %

Some views may show optional equipment.

TMX 20 Series



DRIVING STATION

Standard items :

- Comfortable driver seat and passenger seats on slides
- Electrical horn
- Ignition key switch
- Light and direction indicator selector (Comodo)
- Gauges :
 - Hourmeter
 - Fuel level
- **Indicator lights :**
 - hazard lights
 - Preheating
 - Parking brake
 - Battery charge
 - Water temperature
 - Turn light

OPTIONAL EQUIPMENT

- other engines : PEUGEOT, ISUZU, VOLKSWAGEN (Diesel, Gazoline or LPG).
- Cab with or without doors
- Cab heater
- Suspended driver seat
- Rear hitch manual release from driver seat
- Rotating warning beacon, work light
- Back up alarm
- Rear windscreen wiper
- Front / rear lights protection
- Baggage tray on front bonnet
- Front or/and rear spare wheel
- Other colour than white or 2 colour paint (white Cab)
- Special ignition switch
- Front hitch
- Outside rear view mirrors
- Shock absorbers (front and/or rear)
- Rear lights on cab
- Front windscreen washer
- Gaz tank 60 L. for LPG engine
- Ballast TMX 24 (PERKINS, ISUZU only)
- Ballast TMX 28 (ISUZU only)

DIMENSIONS (TMX20)

Weight: 850 kg (1 873 lbs) (Front axle); 2 300 kg (5 070 lbs) (Rear axle), Total weight: 3 150 kg (6 944 lbs).

Front track: 1 120 mm (44"); Rear track: 1 140 mm (45");

Chassis Ground clearance: 120 mm (4.72");

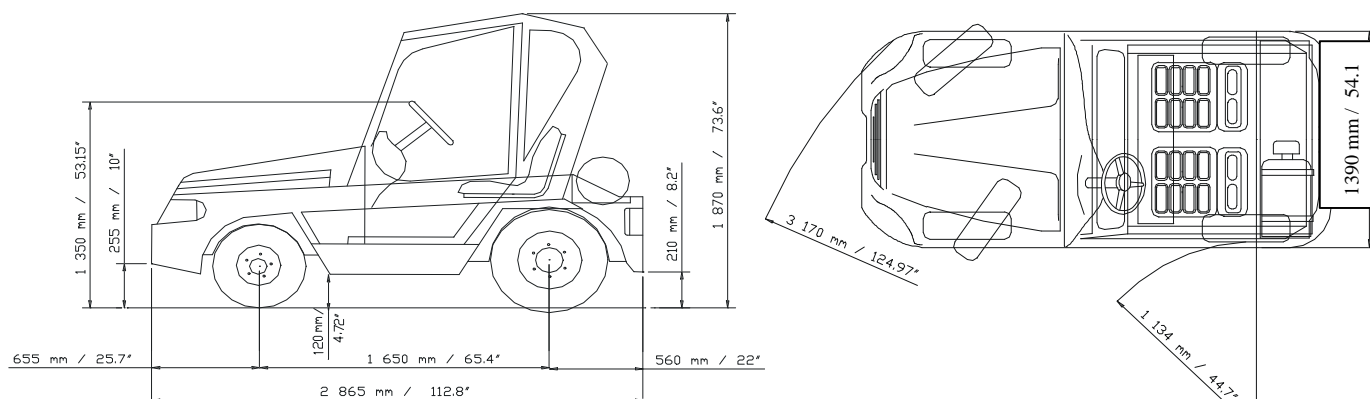

Revised on 10/04/2001

Printed on 10/05/2001

TLD GSE sales group and headquarters :

- **Asia**
TLD-ASIA, Hong Kong
Tel : + 852 2692-2181 Fax : + 852 2691-2604
- **Europe, Africa, Middle East**
TLD-EUROPE, France
Tel : + 33 (0)1 45 60 71 40 Fax : + 33 (0)1 45 60 57 00
- **North & South America**
TLD-AMERICA, USA
Tel : + 1 860 602 34 00 Fax : + 1 860 688 78 95

TUST004D.DOC

T U S T 0 0 4 D

Contactez nous sur notre site web : www.tldgse.com

Specifications may be altered as a constant effort to improve performance.

Tolerance of data : +/- 3 %

Some views may show optional equipment.